

OPTIMISATION OF EXPANSION VALVE CONTROL IN SMALL REFRIGERATION APPLIANCES UNDER CYCLIC OPERATION

M. V. BEEK¹, H. D. JONG¹

¹ Re/genT BV
Helmond, The Netherlands
Tel: +31(0)492 476365, e-mail: marcel.van.beek@re-gent.nl

ABSTRACT

For small refrigeration appliances, capillary tubes are typically applied as expansion device and compressor cycling is used to control product temperature. During the initial minutes after compressor start, the evaporator area is relatively poorly used, resulting in low system efficiency. Improving the evaporator filling during this initial stage improves cycle efficiency.

The current status of an ongoing study is presented outlining the development of a control method for expansion devices in small commercial refrigeration systems. The objective of the study is to improve system efficiency via the control of the expansion device. A provisional control strategy, based on the use of an electronic expansion device with closing valve functionality, is presented and its impact on the cooling system design is discussed. Preliminary validations, using a dedicated test set-up, showed a reduction in energy consumption of 17% for a subcritical (R-404A) and 15% for a transcritical (R-744) cooling system of a vending machine in comparison to its benchmark capillary based system.

1. INTRODUCTION

This paper presents a summary of the ongoing work undertaken under the 7th European Framework Program, with the acronym Expand regarding the development of a low capacity expansion device as possible replacement for capillary tubes in small commercial appliances (i.e. 50 to 750 W cooling capacity range). The focus of the project is to reduce energy consumption in appliances, by the increased utilization of the evaporator area for subcritical refrigeration cycles and through optimizing both the increased utilization of the evaporator area and the discharge pressure for transcritical refrigerating cycles. The Expand project includes the development of a low capacity expansion valve and its control. The valve and the control firmware are outside the scope of this paper. This paper presents the main findings and results and discusses the preliminary control strategy applied in the ongoing development of deriving the control methodology. Within this paper the focus is on subcritical cycles, however, where applicable remarks regarding transcritical operation are also included.

Efforts to improve the efficiency and performance of small capacity refrigeration systems by replacing the capillary tube with a controlled expansion valve were pursued before. Marcinichen et al. (2008) showed considerable energy savings (up to 12.1%) by using an expansion valve instead of a capillary tube in a cassette based cooling system with continuous operation of the variable speed compressor. The same study, however, showed that while the compressor was cycling the capillary tube showed the lowest energy consumption values. Björk (2012) showed that for domestic appliances, using capillary tubes in combination with a low side accumulator provides quite optimal results over a large temperature range. Marcinichen and Melo (2006) evaluated the use of an electronic expansion valve in a domestic refrigerator and showed that the energy consumption of the expansion valve system was only lower than that of the capillary tube system at higher cooling loads and at lower cooling capacities. A remark they made, however, was that the valve orifice and the PID control were not optimized for the evaluated product. Agrawal and Bhattacharyya (2008) compared the performance between using a capillary tube and an optimized expansion valve for a transcritical R-744 heat pump. It was observed that the capillary tube system is actually quite

flexible in response to changes in ambient temperature, creating optimal pressure control just like that of a controllable expansion valve.

The study in this paper shows that compared to capillary tubes, the potential in improving the evaporator filling mainly exists in the transient phase just after compressor activation. Thereby showing largest potential towards appliances having relatively short operating periods (e.g. vending machines) and marginal to no potential for appliances characterized by long operating periods (e.g. chest freezers). From the study it is also shown that refrigerant migration during the off cycle, alongside introducing thermodynamic losses, reduces the potential to improve evaporator filling and cycle optimization.

In the following sections first the results of practical evaluation of the evaporator utilization carried out on 6 reference appliances are presented. Hereafter, in section 3, the relation between evaporator utilization and appliance COP is discussed using a calculation model. This is followed by a section presenting the main findings and presenting the provisional control methodology applied for the practical evaluations. In section 5 the dedicated test set-up used to evaluate the impact of expansion device control on appliance performance and efficiency is presented, followed by the measurement results in section 6. Finally the discussion and conclusions are given.

2. EVAPORATOR UTILIZATION

For 6 commercial refrigeration appliances the evaporator utilization is characterized, see table 1. The characterization is based on estimation of the length of the evaporator tubing containing evaporating refrigerant during the compressor on cycle. This wetted length is estimated by registering the temperature course of multiple thermocouples fitted along the length of the evaporator tube, this during a compressor on cycle at stable conditions, see Fig. 1. For the practical evaluations, the appliances were installed inside a climate chamber, ambient air speed was within 0.1 and 0.25 ms⁻² and the system and ambient temperatures were recorded using T-type thermocouples and a Fluke 2680 data acquisition system, appliance energy consumption was measured using a Yokogawa WT130 power analyzer. The vending machines were loaded with cans (0.33 dm³) and measured according prEN 50597, the beverage cooler was loaded with cans (0.33 dm³) and measured according HE 2013 and the chest freezers were loaded with tylose packages and measured according ISO draft 23953:2013. All testing is performed without performing door opening cycles.

Table 1: Appliances and conditions evaluated

Appliance	Refrigerant	Compressor swept volume [cm ³]	Evaporator	Low Ambient [°C]	Moderate Ambient [°C]	High Ambient [°C]
Vending machine (closed fronted)	R-744	2.5	Fin and tube (forced air)	16	23	32
Vending machine (glass fronted)	R-744	2.5	Fin and tube (forced air)	16	23	32
Vending machine (glass fronted)	R-404A	12.1	Fin and tube (forced air)	16	23	32
Beverage cooler (glass door)	R-600a	9.0	Rollbond (forced air)	16	25	32
Glass lid chest freezer	R-290	6.0	Tubes foamed in (Static)	16	25	30
Glass lid chest freezer	R-290	6.8	Fin and tube (forced air)	16	25	30

Fig. 1 shows that the momentary evaporator filling ratio (FR) starts at 1 (meaning evaporating refrigerant is present over the complete length of the evaporator at compressor start) and drops to 0.18 before increasing to 0.95 at the end of the compressor on cycle. It is also shown that during the first two minutes of the compressor on cycle, the evaporator filling is relatively low (< 0.5). This trend in evaporator filling is quite typical for a properly designed capillary based cooling system operating at its maximum design temperature, i.e. in this case 32 °C. The figure also

shows that for the evaluated appliance a time averaged evaporator filling ratio (\overline{FR} , equation (1)) of 65% results for the compressor on cycle.

$$\overline{FR} = \frac{1}{t} \int_0^t FR dt \quad (1)$$

In table 2 the time averaged evaporator filling has been presented for the 6 evaluated appliances, next to the compressor on-time during a stable operating period. Table 2 shows that the evaporator filling increases with increasing compressor on time. Both chest freezers show a large compressor on time and large evaporator filling ratio at all evaluated ambient temperatures. From this it is concluded that no significant improvement in system efficiency can be expected by improving the evaporator utilization for these appliances. The table also shows that the lowest evaporator filling occurs in the vending machines, thereby indicating largest improvement potential for this type of appliance. The evaluated beverage cooler shows evaporator filling ratios in between the two other appliance categories. From this point onward this paper focuses on the R-404A and the R-744 based glass fronted vending machines.

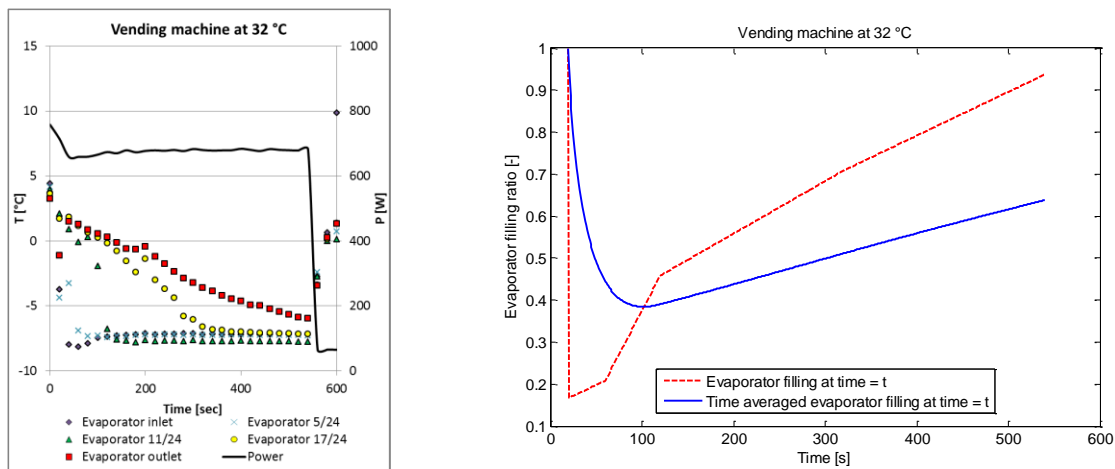

Figure 1: Operating cycle of R-404A based vending machine during steady state operation at an ambient temperature of 32 °C, where time $t = 0$ s indicates the activation of the compressor. Left: Measured evaporator tube temperatures, in which a steep drop in temperature indicates the time at which the two phase flow front approaches the specific position. Right: Momentary (FR) and time averaged (\overline{FR}) evaporator filling during the operating cycle estimated from the temperature readings.

Table 2: Compressor on-time length and time averaged evaporator filling ratio at stable operation.

Appliance	Refrig.	Low Ambient			Moderate Ambient			High Ambient		
		Cycles per hour [h ⁻¹]	On Time [s]	FR [-]	Cycles per hour [h ⁻¹]	On Time [s]	FR [-]	Cycles per hour [h ⁻¹]	On Time [s]	FR [-]
Vending machine (closed fronted)	R-744	2.04	376	0.26	2.40	462	0.34	2.71	588	0.38
Vending machine (glass fronted)	R-744	2.04	272	0.43	2.67	310	0.52	3.00	440	0.71
Vending machine (glass fronted)	R-404A	2.46	274	0.50	2.96	327	0.60	2.98	553	0.65
Beverage cooler (glass door)	R-600a	0.84	1344	0.65	0.51	3568	0.70	0.18	13974	0.78
Glass lid chest freezer	R-290	3.15	627	≈1	1.60	1699	≈1	0.29	11917	≈1
Glass lid chest freezer	R-290	2.36	926	0.96	1.10	2723	≈1	0.00	Inf.	≈1

3. EVAPORATOR UTILIZATION VS. SYSTEM COP

To indicate the effect of evaporator utilization (e.g. evaporator filling) on the performance of a small refrigeration appliance, a calculation model has been set-up in Excel. The model, using REFPROP 9.1 (Lemmon et al, 2013) to determine the refrigerant properties, describes the refrigerant cycle under steady state conditions and calculates the temperature lift and the COP of the cooling system for given heat load (Q), compressor cooling capacity (Q_c), compressor isentropic efficiency (η_i), internal airflow (V), internal air temperature (T_i), ambient air temperature (T_a) and heat exchanger conductance (UA), while assuming a constant subcooling (condenser) and superheating (evaporator) of the refrigerant of 2 K and a suction gas temperature of 25 °C. Fig. 3 presents the results of calculating the systems COP for increasing evaporator utilization of a baseline evaporator with $UA_e = 200 \text{ WK}^{-1}$ at various condenser conductance (UA_c). Note that evaporator utilization is simulated by proportional reduction in UA_e value.

Fig. 3 shows that UA_c , as expected, strongly affects system COP. The relative influence of evaporator utilization on system COP, however, seems to be quite constant for the evaluated UA_c values. Fig. 3 also shows that for the example case, the calculated COP rapidly reduces at utilization levels below 50%, and that the impact of increasing the utilization level from 50 to 100% is only approximately 5% on system COP. The figure also shows that the impact of the utilization is strongly related to the effectiveness of the evaporator. For example; based on an evaporator utilization of 25% (effectiveness = 0.43), a 50% reduction in utilization level (variation between 25 to 12.5%) shows a corresponding reduction in COP of 20%.

The above shows that the influence of evaporator utilization is strongly related to the effectiveness of the evaporator. For high effectiveness, the influence of evaporator utilization is small and at low effectiveness the impact of the utilization is large. In other words, using a relatively large evaporator reduces the need for proper evaporator utilization. Note that the evaluated vending machines show an evaporator effectiveness of 0.6 at 100% utilization. Thereby indicating that for these systems, improvement of COP can be obtained through improvement of evaporator utilization.

For a transcritical cycle, it is commonly known that optimum performance results not only from evaporator utilization but also from optimization of the discharge pressure.

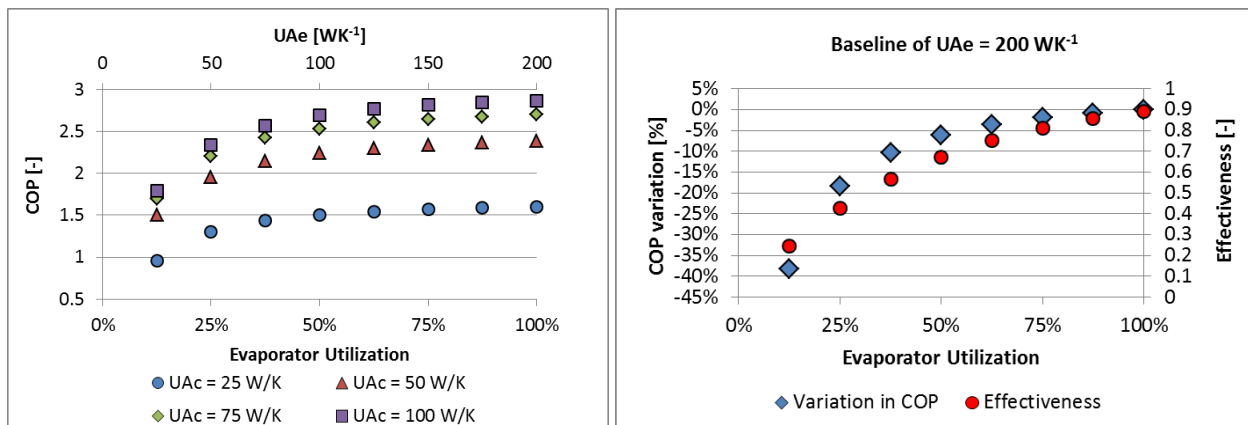

Figure 3: Left: Influence of evaporator utilization on appliance COP for various UA_c values. Right: Reduction in COP with reducing evaporator utilization and corresponding evaporator effectiveness (Janna, 2000), data based on the average COP resulting for the various UA_c values presented in the left figure. Calculations are based on using R-290 as refrigerant, $T_a = 25 \text{ °C}$, $T_i = 2 \text{ °C}$, $V = 350 \text{ m}^3\text{h}^{-1}$, $\eta_i = 0.45$, $Q = 175 \text{ W}$, $Q_c = 350 \text{ W}$ and $UA_e = 200 \text{ WK}^{-1}$.

4 CONTROL STRATEGY AND SYSTEM REQUIREMENTS

For a capillary based system, during the off cycle most of the refrigerant migrates to the evaporator, thereby equalizing the pressure between the warm (i.e. gascooler, condenser) and cold (evaporator) side heat exchanger. At start-up of the compressor, refrigerant is drawn from the evaporator and displaced into the warm side heat exchanger. During this initial phase, due to the low pressure in the warm side heat exchanger, the massflow through

the capillary tube is much lower than the mass displaced by the compressor. Therefore, dry-out results over a large part of the evaporator during this initial phase (e.g. within first minutes) after compressor start. Note that for such an “open” system, during this initial phase, an insufficient quantity of conditioned refrigerant (e.g. subcooled liquid or cold high pressure gas) is present at the inlet of the capillary tube; thereby the evaporator filling cannot be improved by simply increasing the opening of an expansion valve used as a direct replacement of the capillary tube.

Evaporator utilization levels of 100% require “ideal” evaporator filling throughout the complete compressor on cycle, however it is expected that this cannot be achieved. To come as close as possible, based on the findings, the following was applied as a starting point in the control development process.

- Applying a controllable expansion device which opens following an ideal (to be defined) profile.
- Closing of the expansion device during the compressor off cycle, thereby avoiding refrigerant migration from the discharge to the suction line during the compressor off cycle.
- Ensuring a sufficient quantity of refrigerant in the evaporator and of conditioned refrigerant at the inlet of the expansion device at compressor start.

Note that the above requires using a high starting torque compressor as well as some accumulation of refrigerant in the discharge line. For a subcritical system, refrigerant can be accumulated in the high pressure line prior to the expansion device, which can be achieved by clever design of the condenser and connection tubing or by using an additional accumulator. For a transcritical system, sufficient high pressure refrigerant needs to be ensured by proper design of the volume of the warm side heat exchanger and possible connection tubing i.e. during opening of the valve the pressure within the gascooler should not drop below an acceptable level.

For a subcritical system, optimization of system efficiency is based on optimizing the filling of the evaporator during the complete compressor on cycle. During compressor start, more refrigerant is displaced by the compressor than at the end of the on period, therefore the opening of the expansion device should be larger at compressor start and should reduce with time. Due to the redistribution of the refrigerant throughout the evaporator during the off cycle, pre-filling of the evaporator (i.e. opening of the expansion valve prior to the compressor start) could be desirable to minimize local dry out.

For optimization of system efficiency of a transcritical system, both the discharge pressure and the evaporator filling need to be controlled. Therefore, assuming the use of a single valve, control optimization is based on finding the most effective balance in the restriction of the valve throughout the operating cycle.

Each appliance operating condition will have its own ideal opening profile of the expansion device (i.e. profile of cooling down differs from steady state, steady state at 25 °C differs from steady state at 16 °C or 32 °C ambient). Ideally the control (e.g. valve opening profile) auto adapts to changing operating conditions.

As a first step in the control development process and to obtain a quantification of efficiency improvement, “ideal” opening curves were determined through practical validations applying a trial and error approach. Initial testing, of which the results are reported in this paper, was performed applying a linear reduction of valve opening during the compressor on cycle. The impact of pre-filling, applying more complicated opening profiles and finally auto generation and optimization of these curves using embedded controller software, is ongoing and outside the scope of this paper.

Note that during the initial phase after starting of the compressor no proper correlation exists between the filling of the evaporator and the superheat measured at the evaporator outlet. Typically, liquid refrigerant is drawn out of the evaporator at compressor start, while dry out occurs over a large part of the evaporator. In such cases conventional PID based superheat controls will result in closing of the valve, while opening of the valve is desired. Therefore, conventional superheat controls are not considered as an option to improve evaporator filling during the initial phase of the compressor on cycle.

5. TEST RIG

To reduce testing time and measurement uncertainty special test rigs simulating the appliance housing and heat load were constructed. These rigs house the cassette based cooling systems of the R-744 and R-404A glass fronted vending machines, while the evaporator component is fitted inside an insulated box. The box further contains a controllable electrical heater and a thermal buffer composed of containers filled with water (15 dm³), see Fig. 4. To determine the difference in system performance and efficiency between using a capillary and a controlled expansion device, the rigs are equipped with commercially available stepper motor based expansion valves as well as with the original capillary tube, see Fig. 5 and Fig. 6. Closing valves and refrigerant accumulators (only R-404A) are also fitted.

The expansion device of interest can be selected by the switching of a manual valve, Fig 7. Except for requiring refrigerant recharging, no further system modifications were hereby required. To evaluate system performance, the rigs are fitted with multiple thermocouples (Type T, $U_T = 0.3$ K) measuring ambient, internal air, evaporator tube, subcooling (or approach temperature for R-744) and superheating temperatures. In addition, pressure transducers (Keller PAA-33X) are used to measure the discharge and the suction pressure. For data acquisition a Fluke 2680 is used and the power consumption of the cooling system and the internal heater are recorded using Yokogawa WT230 power analyzers ($U_P = 1\%$). The internal air temperature is controlled by computer thermostat and the opening of the expansion valve is controlled using Labview programming and analogue output modules.

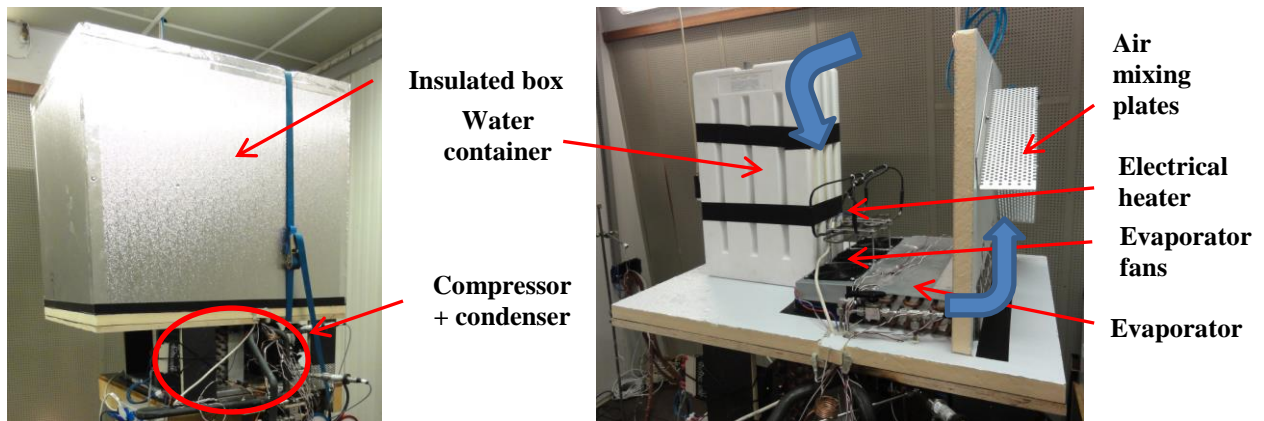

Figure 4: Test rig used to evaluate control strategy “Left: With insulated box, Right: After removal of insulated box, Blue arrows indicating internal air flow direction”

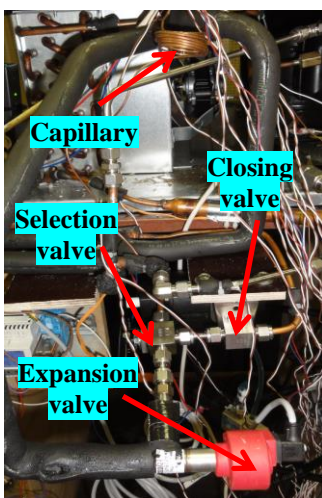

Figure 5: R-744 system

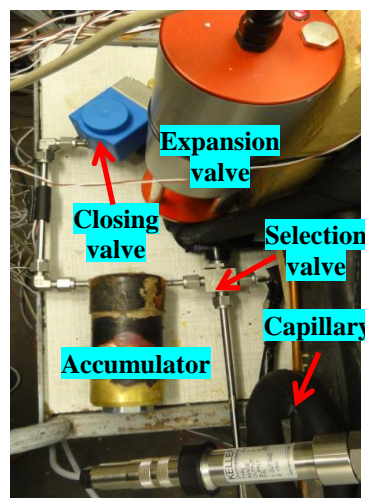

Figure 6: R-404A system

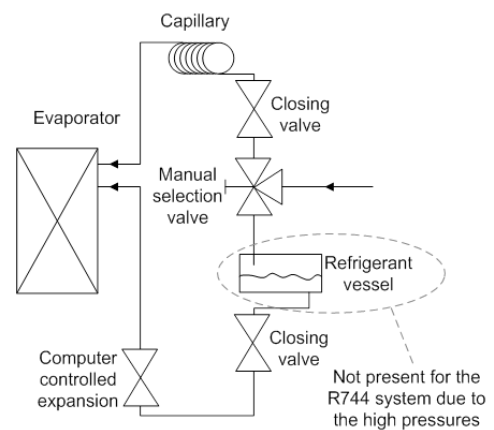

Figure 7: Dual expansion set-up

6. TEST RESULTS

Testing with the rigs is performed inside a climate room at equal ambient conditions to the conditions applied during reference testing of the complete vending machine, see section 2. Also the internal temperature is kept approximately the same as the compartment temperature of the vending machine (within 2 K). Due to the difference in thermal capacity, however, a 50% shorter compressor on time is evident for the rigs in comparison to the vending machines. The power of the electrical heater is regulated in such a way that the total heat load of the box matches the heat load of the vending machine. The utilization of the evaporator is registered using thermocouples fitted along the length of the evaporator tube. The air side cooling capacity (indicator for evaporator heat exchange) is derived from the temperature difference of the air between the evaporator inlet and outlet combined with the estimated volume flow ($310 \text{ m}^3\text{h}^{-1}$), the calculated density and the specific heat of the air. Fig 8 presents the evaporator filling and air side cooling capacity (Q_{air}) for tests performed at equal conditions using the capillary and the controlled expansion device, respectively. In fig 9 the corresponding momentary and time averaged evaporator utilization are shown.

Fig. 8 shows that for operation with the controlled expansion valve a much shorter length of the evaporator is superheated in comparison with the capillary. For example, with the capillary, evaporating refrigerant is reaching the position of 11/24 of the length of the evaporator after 120 seconds, while for the measurement with the valve, evaporating refrigerant is present at this position from 20 seconds onward. The improved evaporator utilization results in an increase in evaporation temperature during the compressor on cycle (i.e. with the capillary approximately $-13 \text{ }^\circ\text{C}$ with the valve varying from -6 to $-12 \text{ }^\circ\text{C}$), a reduced temperature lift and increased efficiency of the cooling system and thereby in a 19.8% reduction in measured energy consumption, see Table 3.

Fig. 9 shows that after start of the compressor (between 10 and 130 seconds) the momentary evaporator filling is very low (< 0.45) for the capillary based configuration. This implies high energy saving potential for using a controlled expansion device during this phase. Fig. 9 also shows that the time averaged evaporator filling with the valve (0.71), as expected, is much larger than obtained with the capillary (0.45). However, especially during the initial part of the compressor on cycle (first 60 seconds), the evaporator filling obtained with the valve is still relatively low (< 0.6), thereby indicating further potential for improvement.

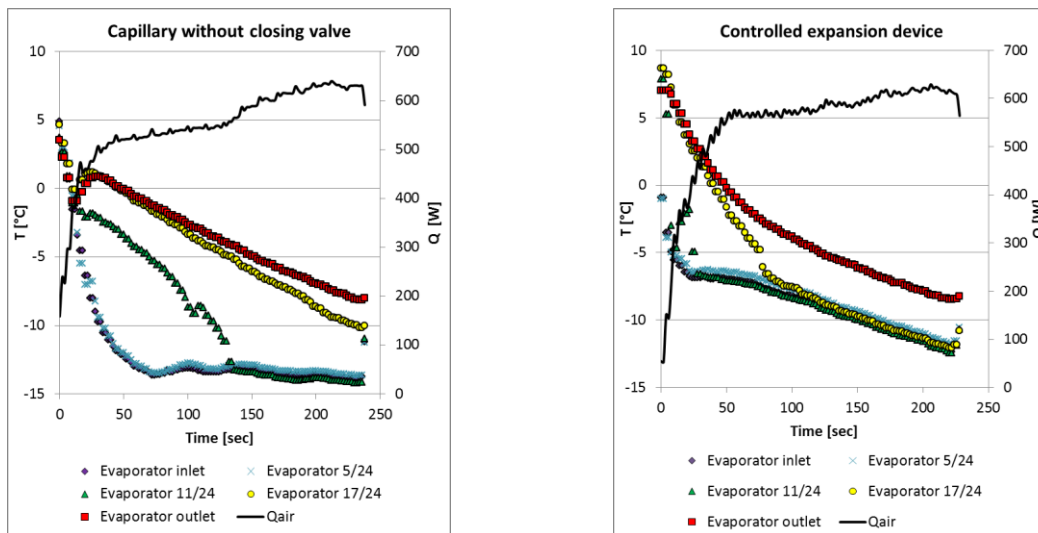

Figure 8: Evaporator filling of R-404A system during compressor on period at an ambient of $23 \text{ }^\circ\text{C}$. “Left: operation with capillary. Right: Operation with controlled expansion valve using optimized linear opening profile”

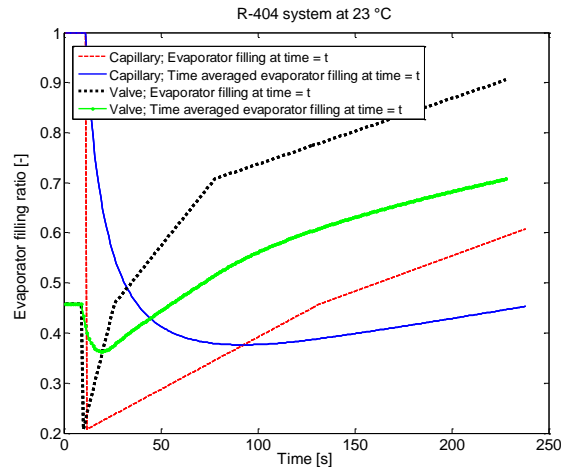

Figure 9: Momentary and time averaged evaporator filling obtained with the capillary and with optimized opening profile of the expansion valve.

The relatively low utilization of evaporator area within the first minute after compressor activation is caused by the limitation of the expansion valve applied. At compressor start the expansion valve (e.g. needle valve) was opened for 100% and the opening was linearly reduced to 76% during the on cycle. Further improvement of evaporator utilization is expected by implementation of a less restrictive expansion valve for this system.

Energy consumption testing has been conducted applying three configurations, namely;

- Configuration A; test rig operating with the capillary tube, without operating the closing valve.
- Configuration B; test rig operating with the capillary tube, with closing valve operation.
- Configuration C; test rig operating with the controlled expansion valve, with closing valve operation.

The measurement results for the subcritical (R-404A) system are presented in Table 3. In Table 4 the provisional results of measurements performed on the transcritical (R744) rig are given. Note that the testing with the capillary tube is performed applying optimum refrigerant charge for 23 °C ambient conditions (i.e. refrigerant charge resulting in the lowest energy consumption at 23 °C ambient).

Table 3: Measured energy consumption of the subcritical cooling system and the number of operating cycles per hour for capillary configuration. Energy consumption includes the power consumption of the compressor, the condenser fan (47.5 W, cycling with the compressor) and the power consumption of the evaporator fan (31 W, operating continuously). Uncertainty based on 95% confidence interval.

Ambient	No. Cycles	Configuration A	Configuration B	Configuration C	Comparing B and A	Comparing C and A
[°C]	[1/h]	[kWh/d]	[kWh/d]	[kWh/d]	[%]	[%]
16	5.2	3.75 ± 0.08	3.33 ± 0.08	3.17 ± 0.08	-11.2 ± 3.1	-15.5 ± 3.1
23	5.3	4.69 ± 0.09	4.14 ± 0.09	3.76 ± 0.08	-11.7 ± 2.7	-19.8 ± 2.7
32	5.6	7.48 ± 0.12	6.72 ± 0.11	6.30 ± 0.11	-10.1 ± 2.2	-15.8 ± 2.2

Table 4: Provisional results of measured energy consumption of the transcritical cooling system and the number of operating cycles per hour for the capillary configuration. Energy consumption includes power consumption of compressor and the condenser fan (47.5 W, cycling with compressor). Uncertainty based on 95% confidence interval.

Ambient	No. Cycles	Configuration A	Configuration B	Configuration C	Comparing B and A	Comparing C and B
[°C]	[1/h]	[kWh/d]	[kWh/d]	[kWh/d]	[%]	[%]
23	2.5	5.0 ± 0.08	4.81 ± 0.08	Not measured	-3.8 ± 2.7	-
32	4.6	Not measured	8.06 ± 0.10	6.83 ± 0.10	-	-15.3 ± 2.1

Table 3 and Table 4 show on average approximately 17% and 15% reduction in energy consumption respectively, for the use of the expansion valve in comparison to the original capillary tube for the subcritical and the transcritical system. Table 3 also shows that approximately 11% reduction in energy consumption results for fitting a closing valve in the original capillary based subcritical configuration. For the transcritical system a much smaller (3.8%) impact of the closing valve is observed during the preliminary evaluations performed on this system.

8. DISCUSSION

The provisional measurement results show a large reduction in system energy consumption by using closing valve functionality. A closing valve avoids migration of refrigerant from the high pressure circuit (i.e. discharge tubing, condenser) towards the evaporator during compressor off cycle. The thermodynamic losses associated with this migration strongly depend on the cooling system design and the operating conditions and are almost constant per operating cycle (Janssen, 1989). Therefore, the larger the frequency of operating cycles the larger the losses. For the evaluations performed on the subcritical test rig, the frequency of operating cycles (6 h^{-1}) is approximately two times larger than the frequency of operating cycles for the glass fronted vending machine (3 h^{-1}). Therefore, to obtain a proper estimation of the influence of closing valve functionality on the evaluated vending machine, the measured energy consumption reduction should be corrected for the frequency of operating cycles. From the measurement results, Table 3, it can be observed that for the evaluated system, applying closing valve functionality results in a cyclic energy consumption reduction of approximately 2% per operating cycle. Since the test rig cooling system is equal to the cooling system applied in the glass fronted vending machine, it can be estimated that including closing valve functionality will result in an approximately 6% reduction in the energy consumption of the capillary based cooling system of the glass fronted vending machine.

A cooling system ideally operates at very small temperature differential to keep the thermodynamic loss (operation at increased temperature lift) as small as possible. For a fixed capacity compressor and capillary based system, this would result in operation at short compressor on periods. This in turn typically results in relatively poor utilization of the evaporator and in relatively large migration losses. These two opposing effects result in a design specific, optimum cycling frequency. Using a controllable expansion valve including closing valve functionality, opens the possibility to design towards higher cycling frequencies, thereby further increasing system efficiency in comparison to the benchmark capillary based systems.

Instead of increasing system efficiency, improved evaporator utilization can be applied to increase system compactness at equal efficiency.

9. CONCLUSIONS

Compared to a capillary based cooling system, the main potential in energy consumption reduction is in improving the evaporator utilization during the first minutes after compressor activation.

Calculations showed that the influence of evaporator utilization on cooling system efficiency is strongly related to the effectiveness of the evaporator. For high effectiveness, the influence of evaporator utilization is small and at low effectiveness the impact of the utilization is large.

Vending machines showed the largest potential for improvement in comparison to the other evaluated systems. These appliances are characterized by low evaporator utilization, short compressor on time and relatively high compressor cycling frequencies.

The practical findings indicated that to improve evaporator utilization after compressor start, a controllable valve, closing valve functionality and accumulation of refrigerant in the discharge line are needed. This results in the requirement of a high starting torque compressor as well as clever design of the discharge line.

As a first step in the control development process and to obtain a quantification of efficiency improvement, “ideal” opening curves were determined through practical validations applying a trial and error approach. Initial testing, using a dedicated test set-up and applying linear reduction of valve opening, showed approximately 17% and 15% reduction in energy consumption for an R-404A and R-744 based cooling systems respectively, in comparison to

using a capillary tube. Thereby showing that for some appliance types significant energy consumption reduction can be obtained by improving the evaporator utilization during the first minutes after compressor activation through the use of a controlled expansion valve with closing valve functionality. However a large part of this reduction is due to the closing functionality of the valve during the compressor off phase.

Further improvement in evaporator utilization (and discharge pressure optimization for transcritical cycles) can be achieved by optimization of the valve opening profile. The main difficulty and the main subject of the ongoing work, is to derive control algorithms which automatically determine these “ideal” opening profiles and to auto adjust for varying operating conditions. Within this current work more complicated profiles are foreseen, including possible prefilling of the evaporator.

NOMENCLATURE

COP	Coefficient of Performance	(-)	T_a	Ambient temperature	(°C)
FR	Momentary evaporator filling ratio	(-)	U	Expanded uncertainty (k = 2, 95% confidence)	
\overline{FR}	Time averaged evaporator filling ratio	(-)	UA_c	Conductance warm side heat exchanger	(WK ⁻¹)
Q	Heatload / Heat absorption	(W)	UA_e	Conductance evaporator	(WK ⁻¹)
Q_c	Compressor cooling capacity	(W)	V	Airflow	(m ³ h ⁻¹)
t	time	(s)	η_i	Isentropic efficiency	(-)
T_i	Internal temperature	(°C)			

REFERENCES

- Agrawal, N., Bhattacharyya, S. (2008), Optimized transcritical CO₂ heat pumps: Performance comparison of capillary tubes against expansion valves, *Int. J. of refrigeration*, Volume 31, P. 388-395.
- Bjork, E. (2012), *Energy Efficiency Improvements in Household Refrigeration Cooling Systems Doctoral Thesis*, Trita REFR Report 12/02, Royal Institute of Technology, Stockholm.
- HE (2013), *Fridges specification & test protocol Version. 3.1, Heineken International, Amsterdam, 30 p.*
- Janna, W.S. (2000). *Engineering heat transfer*, Boca Raton, CRC Press LLC.
- Janssen, M.J.P (1989), *Cycling losses in cooling circuits MSc Thesis*, WOP-WET 89.002, Eindhoven University of Technology, Eindhoven
- Lemmon, E.W., Huber, M.L., McLinden, M.O. NIST Standard Reference Database 23: Reference Fluid Thermodynamic and Transport Properties-REFPROP, Version 9.1, National Institute of Standards and Technology, Standard Reference Data Program, Gaithersburg, 2013.
- Marcinichen, J. B., Schurt, L. C., Melo, C., Vieira, L. A. T. (2008), Performance Evaluation of a Plug-In Refrigeration System Running Under the Simultaneous Control of Compressor Speed and Expansion Valve Opening, *Proceedings of the 12th International Refrigeration and Air Conditioning Conference, Purdue, US (Paper 921)*. Purdue, US: Purdue University
- Marcinichen, J. B., Melo, C. (2008), Comparative Analysis Between a Capillary Tube and an Electronic Expansion Valve in a Household Refrigerator, *Proceedings of the 11th International Refrigeration and Air Conditioning Conference, Purdue, US (Paper 838)*. Purdue, US: Purdue University.

ACKNOWLEDGEMENT

This work has been conducted by the Expand Consortium sponsored by the E.U., under the FP7 framework, consisting of the EUROPEAN VENDING ASSOCIATION (Belgium), Vending Marketing (Slovenia), NOVUM (OVERSEAS) Ltd (Ireland), FRIGOCON SA (Portugal), NEW WAVE INNOVATIONS Ltd (U.K.), INRAY SOLUTIONS Ltd (Bulgaria) and Re/genT BV (the Netherlands). All assistance is gratefully acknowledged.